

**SMD LED (Top View Type 3020 Pre Mold Lead Frame) 外觀圖示**

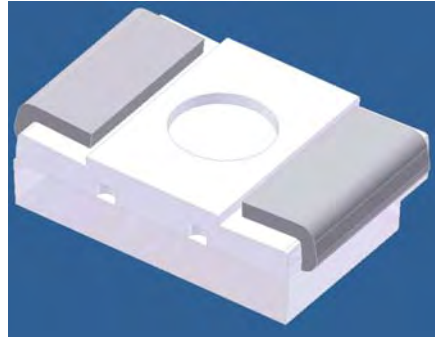
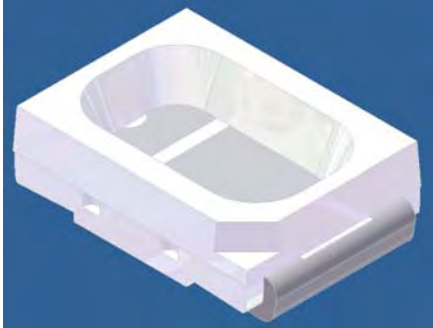

**物理性質**

發光角: 120°  
 電氣傳導率: 85 min. %IACS  
 熱傳導率: 347 W/m.k  
 抗拉強度: 295~375 N/mm<sup>2</sup>  
 熱膨脹係數: 17.7 10<sup>-6</sup>/°C  
 塑膠軟化點: 318°C at(0.45MPa)  
 融化點: 321°C  
 吸濕率: 0.1% (24hrs)

**機械性質**

尺寸: 3.0x 2.0x 1.3 mm  
 銅底材材質: TAMAC-4 or CDA 194  
 塑膠材質: PPA 4122-117, 678 ,TA-112, NM114NS  
 接腳數: 2 PIN  
 電鍍: 全鍍+單面選鍍銀  
 電鍍膜厚:  
 Option 1:Flash Ag 0.127um min+ Spot Ag 2.5um min.  
 Option 2:Flash Ag 1.5um min+ Spot Ag 3um min.  
 料片尺寸: 144(L)x 49(W)x 0.15(T)mm  
 單片顆數: 288 Pcs

**機械尺寸**

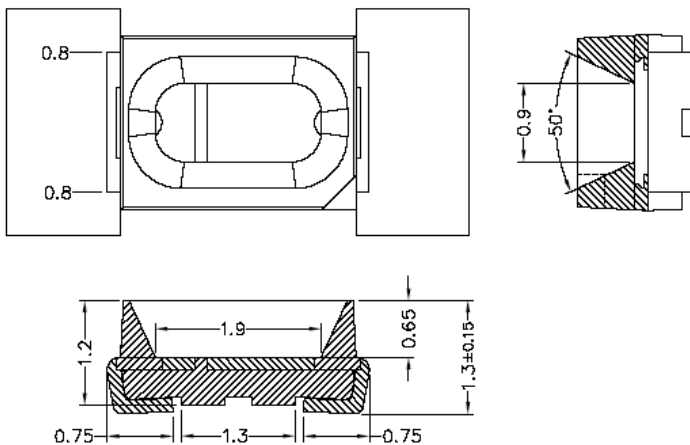

**產品應用**

中小尺寸 LCD 背光 LED  
 信號顯示燈  
 閃光燈

