

**SMD LED (Side View Type 020 Pre Mold Lead Frame) 外觀圖示**

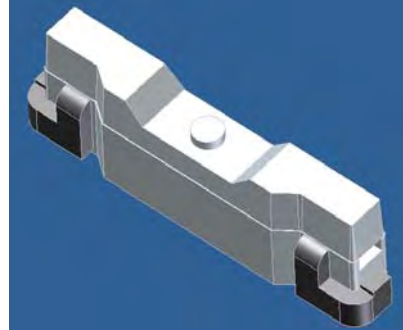
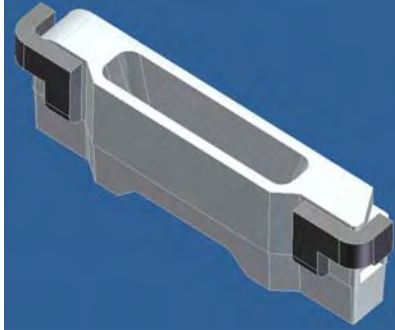

**物理性質**

發光角: 110°  
 電氣傳導率: 85 min. %IACS  
 熱傳導率: 347 W/m.k  
 抗拉強度: 295~375 N/mm<sup>2</sup>  
 熱膨脹係數: 17.7 10<sup>-6</sup>/°C  
 塑膠軟化點: 318°C at(0.45MPa)  
 融化點: 321°C  
 吸濕率: 0.24% (24hrs)

**機械性質**

尺寸: 3.5x 0.6x 1.2 mm  
 銅材材質: TAMAC-4 and CDA 194  
 塑膠材質: PPA A4122 WH 117  
 接腳數: 2 PIN  
 電鍍: 全鍍+單面選鍍銀  
 電鍍膜厚: Flash Ag 0.127um min+ Spot Ag 3~8um  
 料片尺寸: 144(L)x 49(W)x 0.15(T)mm  
 單片顆數: 240 Pcs

**機械尺寸**

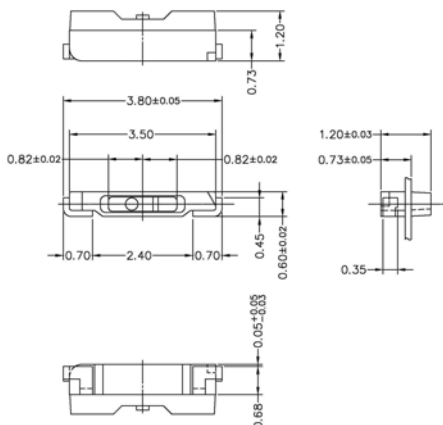

**產品應用**

背光板  
 手機按鍵

